

- NOTES:
1. DIMENSIONS WITHIN THE PARENTHESES ARE METRIC UNITS (millimeters) or (Kg=Kilograms)
 2. MATERIAL: FIBERGLASS REINFORCED POLYMER (FRP)
 3. WEIGHT:

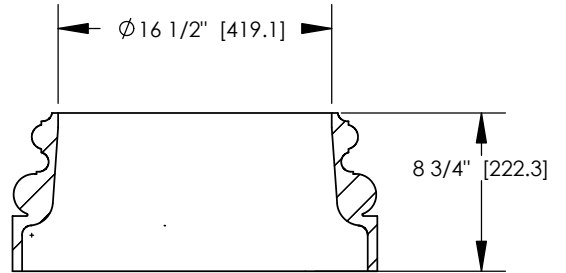

SECTION A-A
SCALE 1 : 10

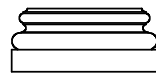
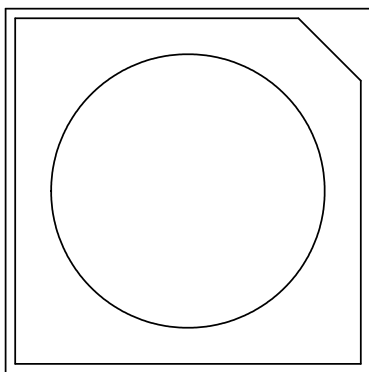
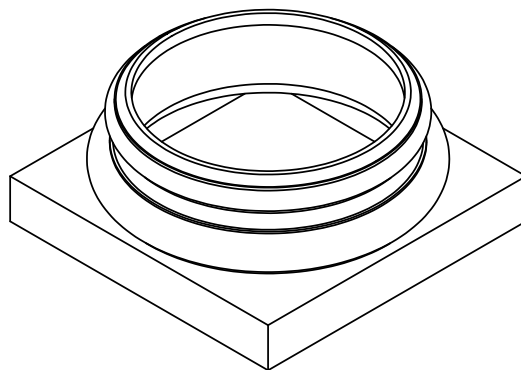
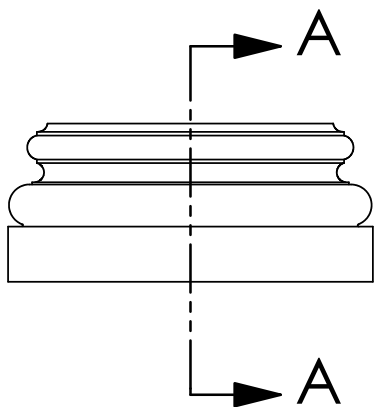

ARCHITECTURAL
VIEW
SCALE: 1/25

Column & Post, Inc.TM
8013 Purfoy Road
Fuquay-Varina, NC 27526
Tel: (919) 255-1533
Fax: (919) 255-1553
E-Mail: www.columnpost.com

		DIMENSIONS ARE IN INCHES TOLERANCES: FRACTIONAL ±1/8 ANGULAR: MACH ± BEND ± TWO PLACE DECIMAL ± THREE PLACE DECIMAL ±
		MATERIAL
		FINISH
NEXT ASSY	USED ON	
APPLICATION		DO NOT SCALE DRAWING

	NAME	DATE
DRAWN	SOF	05/05/08
CHECKED	RK	
ENG APPR.	RK	
MFG APPR.	RK	
Q.A.	RK	

COMMENTS:

© COPYRIGHT
COLUMN & POST, Inc. 2002

ATTIC 16 INCH
BASE

SIZE A	DWG. NO.	REV. 02
SCALE: NONE		SHEET 1 OF 1