

NOTES:

1. DIMENSIONS WITHIN THE PARENTHESES ARE METRIC UNITS (millimeters) or (Kg=Kilograms)
2. MATERIAL: FIBERGLASS REINFORCED POLYMER (FRP)
3. WEIGHT: 5 Lb. (2.3 Kg)

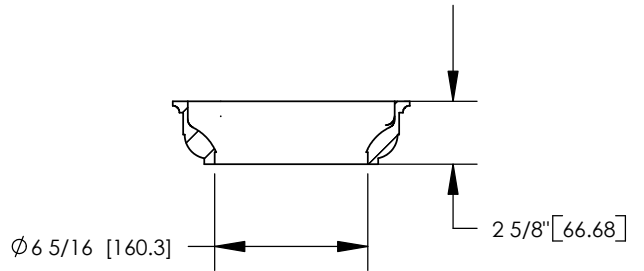

SECTION A-A
SCALE 1 : 8

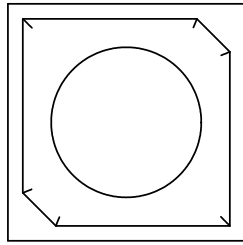
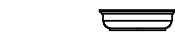
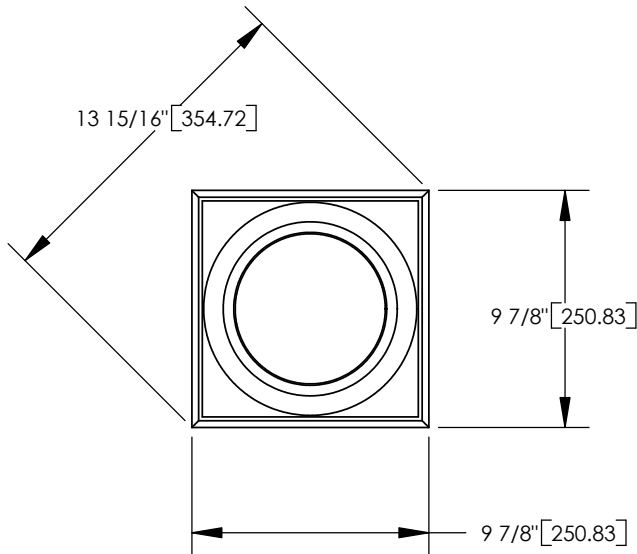
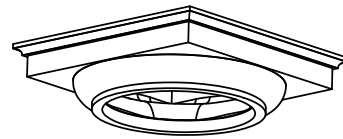
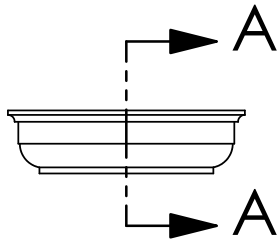

ARCHITECTURAL
VIEW
SCALE: 1/25

Column & Post, Inc.™
8013 Purfoy Road
Fuquay-Varina, NC 27526
Tel: (919) 255-1533
Fax: (919) 255-1553
E-Mail: www.columnpost.com

		DIMENSIONS ARE IN INCHES (mm)		NAME	DATE	©COPYRIGHT Column & Post, Inc. 2002 DORIC 8 INCH CAP	
		TOLERANCES:		DRAWN	SOF		05/05/08
		FRACTIONAL ± 1/8"		CHECKED	RK		
		ANGULAR: MACH ±		ENG APPR.	RK		
		BEND ±		MFG APPR.	RK		
		TWO PLACE DECIMAL ±		Q.A.	RK		
		THREE PLACE DECIMAL ±		COMMENTS:			
		MATERIAL					
NEXT ASSY	USED ON	FINISH				SIZE DWG. NO.	
APPLICATION		DO NOT SCALE DRAWING				REV. 02	
				SCALE: 1/8		WEIGHT: SHEET 1 OF 1	