

NOTES:

1. DIMENSIONS WITHIN THE PARENTHESES ARE METRIC UNITS (millimeters) or (Kg=Kilograms)
2. MATERIAL: FIBERGLASS REINFORCED POLYMER (FRP)
3. WEIGHT: 14 Lb. (6.4 Kg)

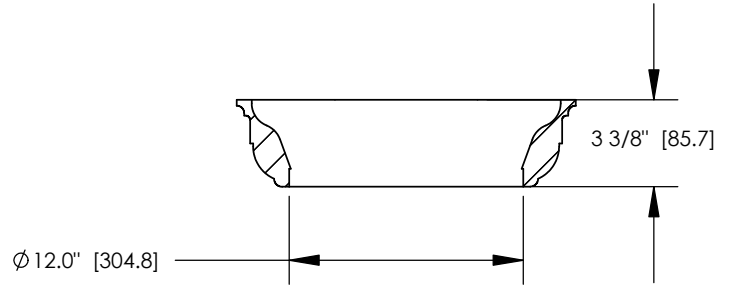

SECTION A-A
SCALE 1 : 8

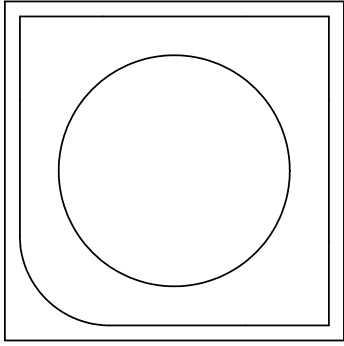
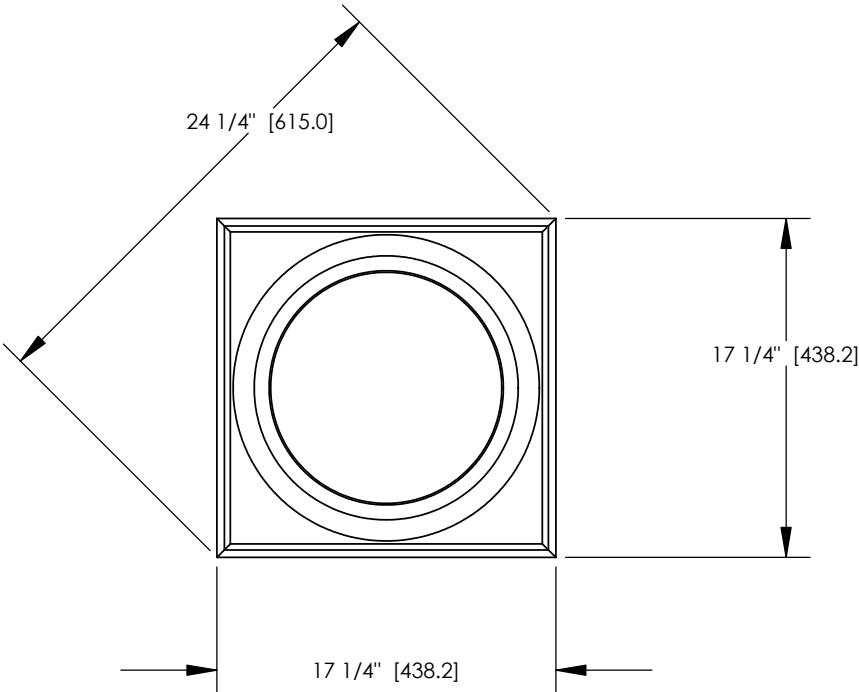
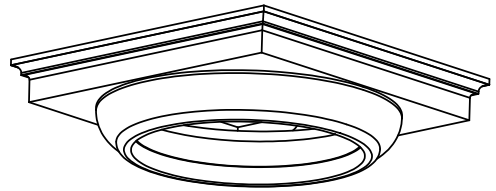
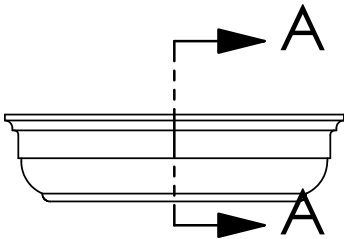

ARCHITECTURAL
VIEW
SCALE: 1/25

Column & Post, Inc.™
8013 Purfoy Road
Fuquay-Varina, NC 27526
Tel: (919) 255-1533
Fax: (919) 255-1553
E-Mail: www.columnpost.com

		DIMENSIONS ARE IN INCHES (mm) TOLERANCES: FRACTIONAL ± 1/8" ANGULAR: MACH ± BEND ± TWO PLACE DECIMAL ± THREE PLACE DECIMAL ±	NAME	DATE	©COPYRIGHT Column & Post, Inc. 2002	
			DRAWN	SOF		05/05/08
			CHECKED	RK		
			ENG APPR.	RK.		
		MATERIAL	MFG APPR.	RK		
		FINISH	Q.A.	RK		
NEXT ASSY	USED ON		COMMENTS:			
APPLICATION		DO NOT SCALE DRAWING				
SIZE	DWG. NO.			REV.		
A				02		
SCALE: 1/8		WEIGHT:		SHEET 1 OF 1		

DORIC 14 INCH CAP