

DORIC CAP

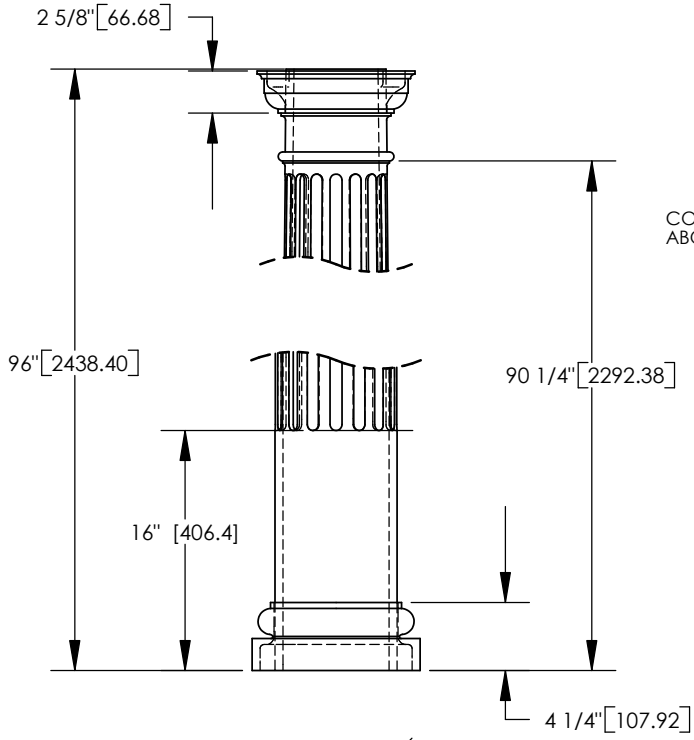

COLUMN PROJECTS 1/8" (3.18) ABOVE STANDARD CAPITAL.

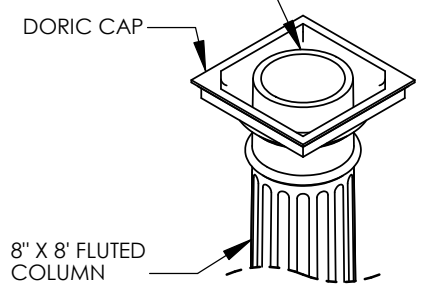

8" X 8" FLUTED COLUMN

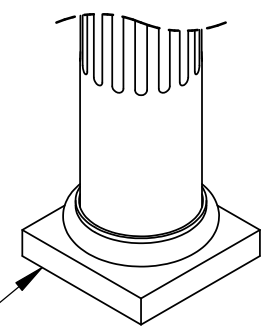

TUSCAN BASE

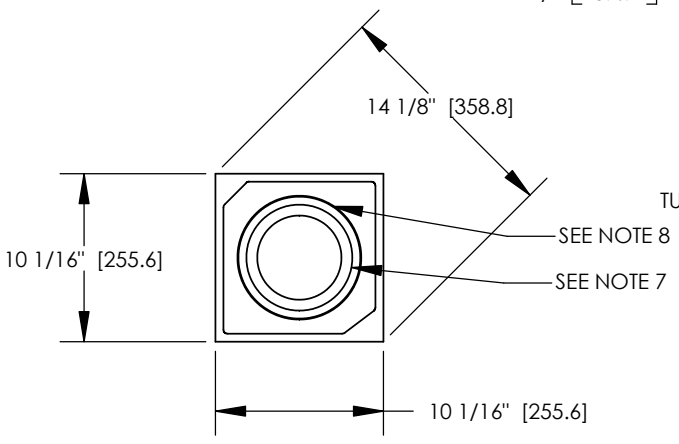

TUSCAN BASE

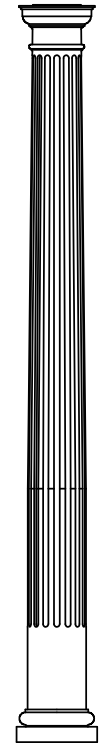

ARCHITECTURAL VIEW  
SCALE 1/25

- NOTES:
1. DIMENSIONS WITHIN THE PARENTHESES ARE METRIC UNITS (millimeters) or (Kg=Kilograms)
  2. MATERIAL: FIBERGLASS REINFORCED POLYMER (FRP)
  3. WEIGHT. COLUMN: 50 Lb. (22.7 Kg)  
CAP: 5 Lb. (2.3 Kg)  
BASE: 7 Lb. (3.2 Kg)
  4. MATERIAL THICKNESS. COLUMN: 3/8" (9.5)
  5. INSIDE DIAMETER AT TOP OF COLUMN: 5.0" (127.0)
  6. OUTSIDE DIAMETER AT TOP OF COLUMN: 6.0" [152.4]
  7. INSIDE DIAMETER AT BOTTOM OF COLUMN: 6 7/8" (174.6)
  8. OUTSIDE DIAMETER AT BOTTOM OF COLUMN: 7 1/2" (190.5)
  9. TAPER STARTS 29" (736.6) FROM BOTTOM OF COLUMN.
  10. 16 FLUTES

DIMENSIONS ARE IN INCHES (mm)  
TOLERANCES:  
FRACTIONAL: ± 1/8"  
ANGULAR: MACH ±  
BEND ±  
TWO PLACE DECIMAL ±  
THREE PLACE DECIMAL ±

DRAWN	SOF	DATE	05/05/08
CHECKED	RK		
ENG APPR.	RK		
MFG APPR.	RK		
Q.A.	RK		

©COPYRIGHT  
Column & Post, Inc. 2002  
**8" X 8" FLUTED COLUMN  
W/ DORIC CAP  
& TUSCAN BASE  
ASSEMBLY**

Column & Post, Inc.™  
8013 Purfoy Road  
Fuquay-Varina, NC 27526  
Tel: (919) 255-1533  
Fax: (919) 255-1553  
E-Mail: www.columnpost.com

NEXT ASSY	USED ON	FINISH
APPLICATION		DO NOT SCALE DRAWING

SIZE	DWG. NO.	REV.
<b>A</b>		<b>02</b>
SCALE: 1/12	WEIGHT:	SHEET 1 OF 1