

NOTES:

1. DIMENSIONS WITHIN THE PARENTHESES ARE METRIC UNITS (millimeters) or (Kg=Kilograms)
2. MATERIAL: FIBERGLASS REINFORCED POLYMER (FRP)
3. WEIGHT. COLUMN: 75 Lb. (34.0 Kg)
CAP: 5 Lb. (2.3 Kg)
BASE: 7 Lb. (3.2 Kg)
4. MATERIAL THICKNESS.
COLUMN: 3/8" (9.5)
5. INSIDE DIAMETER AT TOP OF COLUMN: 5 1/2" (139.7)
6. OUTSIDE DIAMETER AT TOP OF COLUMN: 6.0" (152.4)
7. INSIDE DIAMETER AT BOTTOM OF COLUMN: 6 5/8" (168.3)
8. OUTSIDE DIAMETER AT BOTTOM OF COLUMN: 7 1/2" (190.5)
9. TAPER STARTS 42" (1066.8) FROM BOTTOM OF COLUMN.
10. 16 FLUTES

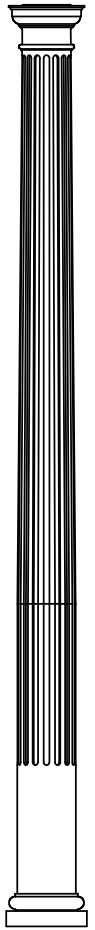
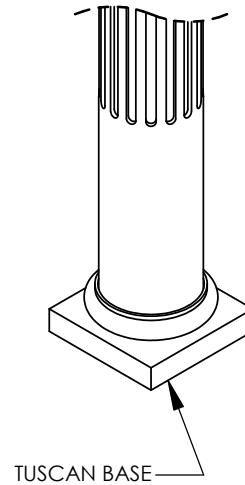
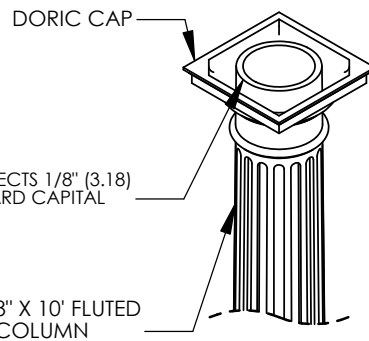
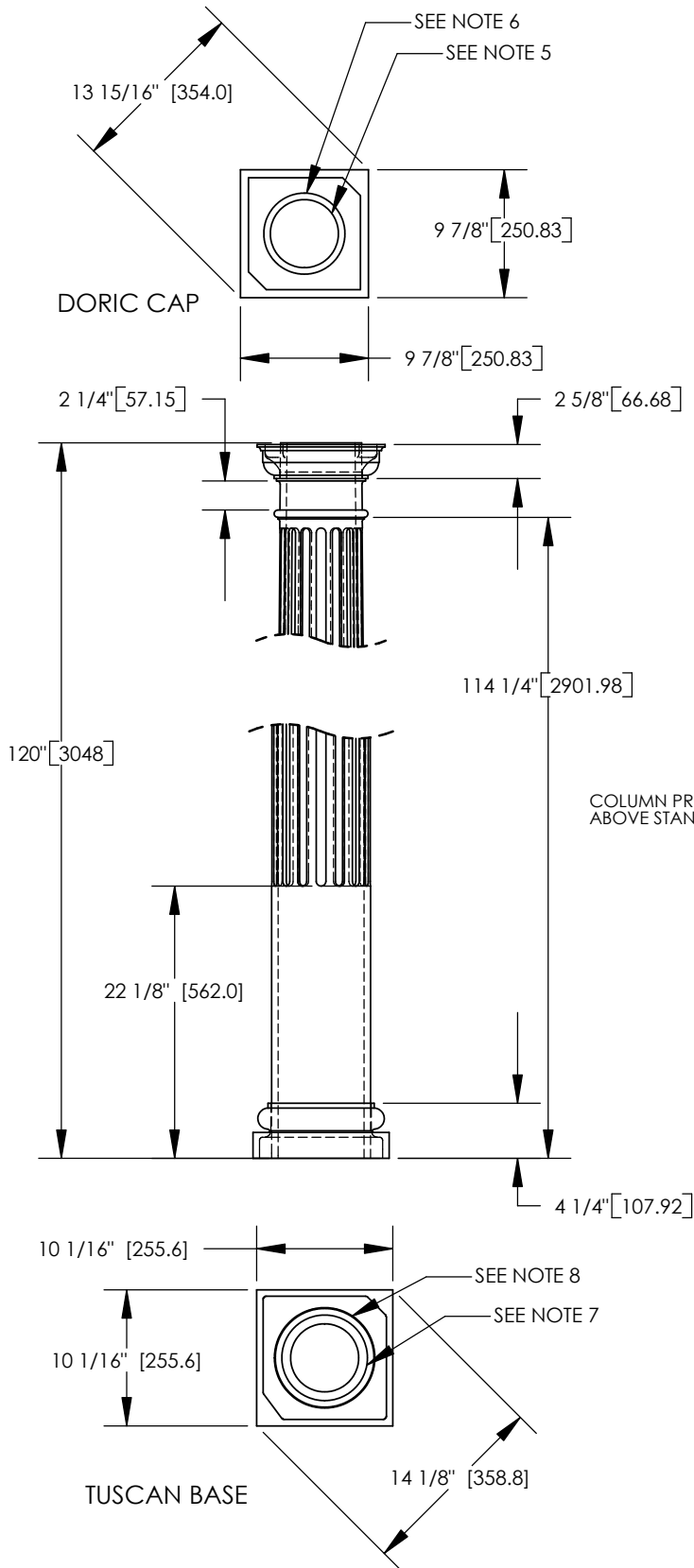

ARCHITECTURAL VIEW
SCALE 1/25

Column & Post, Inc.™
8013 Purfoy Road
Fuquay-Varina, NC 27511
Tel: (919) 255-1533
Fax: (919) 255-1553
E-Mail: www.columnpost.com

		DIMENSIONS ARE IN INCHES (mm) TOLERANCES: FRACTIONAL ± 1/8" ANGULAR: MACH ± BEND ± TWO PLACE DECIMAL ± THREE PLACE DECIMAL ±			
			MATERIAL		
NEXT ASSY	USED ON		FINISH		
APPLICATION			DO NOT SCALE DRAWING		

	NAME	DATE
DRAWN	SOF	05/05/08
CHECKED	RK	
ENG APPR.	RK	
MFG APPR.	RK	
Q.A.	RK	
COMMENTS:		

© COPYRIGHT Column & Post, Inc. 2002		
8" X 10' FLUTED COLUMN W/ DORIC CAP & TUSCAN BASE ASSEMBLY		
SIZE A	DWG. NO.	REV. 02
SCALE: 1/14	WEIGHT:	SHEET 1 OF 1