

- NOTES:
1. DIMENSIONS WITHIN THE PARENTHESES ARE METRIC UNITS (millimeters) or (Kg=Kilograms)
  2. MATERIAL: FIBERGLASS REINFORCED POLYMER (FRP)
  3. WEIGHT. COLUMN: 83 Lb. (37.6 Kg)  
CAP: 8 Lb. (3.6 Kg)  
BASE: 15 Lb. (6.8 Kg)
  4. MATERIAL THICKNESS. COLUMN: 3/8" (9.5)
  5. INSIDE DIAMETER AT TOP OF COLUMN: 6 5/8" (168.3)
  6. OUTSIDE DIAMETER AT TOP OF COLUMN: 7 1/2" (190.5)
  7. INSIDE DIAMETER AT BOTTOM OF COLUMN: 8 3/4" [222.3]
  8. OUTSIDE DIAMETER AT BOTTOM OF COLUMN: 9 5/8" (244.5)
  9. TAPER STARTS 24.0" (609.6) FROM BOTTOM OF COLUMN.
  10. 20 FLUTES

COLUMN PROJECTS 1/8" (3.18) ABOVE STANDARD CAPITAL.

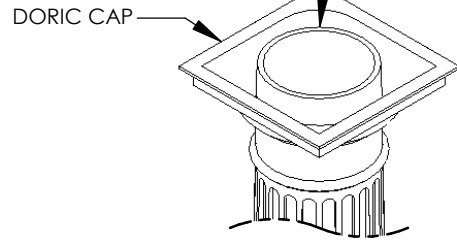

10" X 8' FLUTED COLUMN

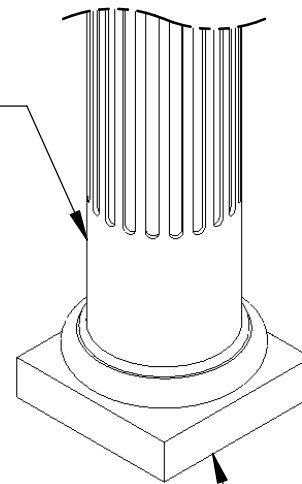

TUSCAN BASE

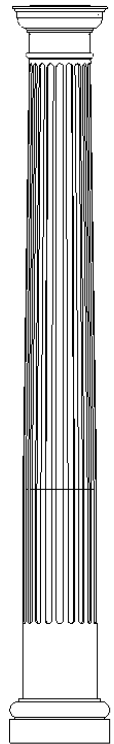

ARCHITECTURAL VIEW  
SCALE 1/25

TUSCAN BASE

			DIMENSIONS ARE IN INCHES (mm) TOLERANCES: FRACTIONAL: ± 1/8" ANGULAR: MACH ± BEND ± TWO PLACE DECIMAL ± THREE PLACE DECIMAL ±		
			MATERIAL		
			FINISH		
	NEXT ASSY	USED ON			
	APPLICATION		DO NOT SCALE DRAWING		

	NAME	DATE
DRAWN	SOF	05/05/08
CHECKED	RK	
ENG APPR.	RK	
MFG APPR.	RK	
Q.A.	RK	
COMMENTS:		

©COPYRIGHT  
Column & Post, Inc. 2002

10" X 8' FLUTED COLUMN  
W/DORIC CAP  
& TUSCAN BASE  
ASSEMBLY

Column & Post, Inc.™  
8013 Purfoy Road  
Fuquay-Varina, NC 27511  
Tel: (919) 255-1533  
Fax: (919) 255-1553  
E-Mail: www.columnpost.com

SIZE	DWG. NO.	REV.
A		02
SCALE: 1/12	WEIGHT:	SHEET 1 OF 1