

NOTES:

1. DIMENSIONS WITHIN THE PARENTHESES ARE METRIC UNITS (millimeters) or (Kg=Kilograms)
2. MATERIAL: FIBERGLASS REINFORCED POLYMER (FRP)
3. WEIGHT. COLUMN: 90 Lb. (40.8 Kg)
CAP: 14 Lb. (6.4 Kg)
BASE: 17 Lb. (7.7 Kg)
4. MATERIAL THICKNESS. COLUMN: 3/8" (9.5)
5. INSIDE DIAMETER AT TOP OF COLUMN: 8 1/4" (209.6)
6. OUTSIDE DIAMETER AT TOP OF COLUMN: 9 3/8" (238.1)
7. INSIDE DIAMETER AT BOTTOM OF COLUMN: 10 3/4" (273.0)
8. OUTSIDE DIAMETER AT BOTTOM OF COLUMN: 11 3/8" (288.9)
9. TAPER STARTS 22.0" (558.8) FROM BOTTOM OF COLUMN.
10. 24 FLUTES

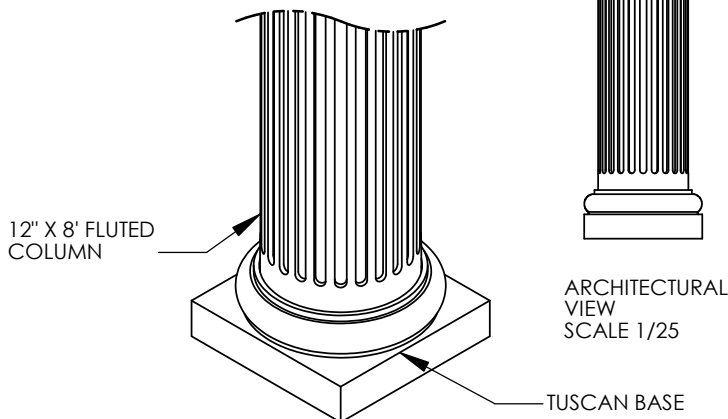
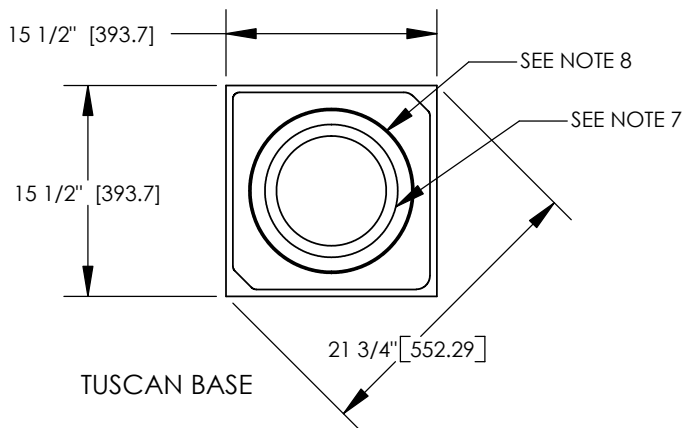
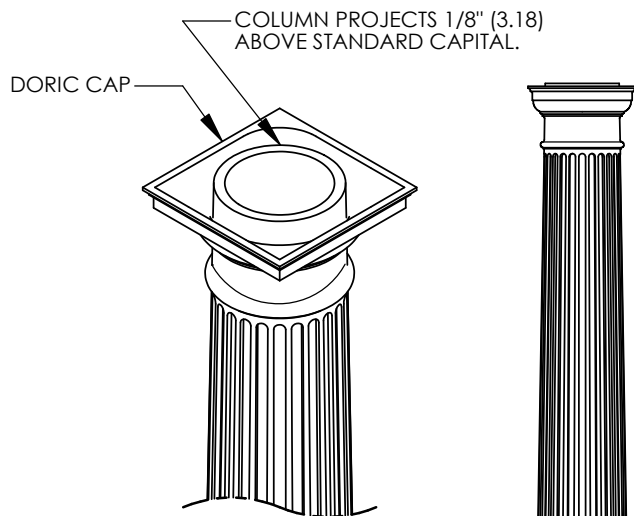
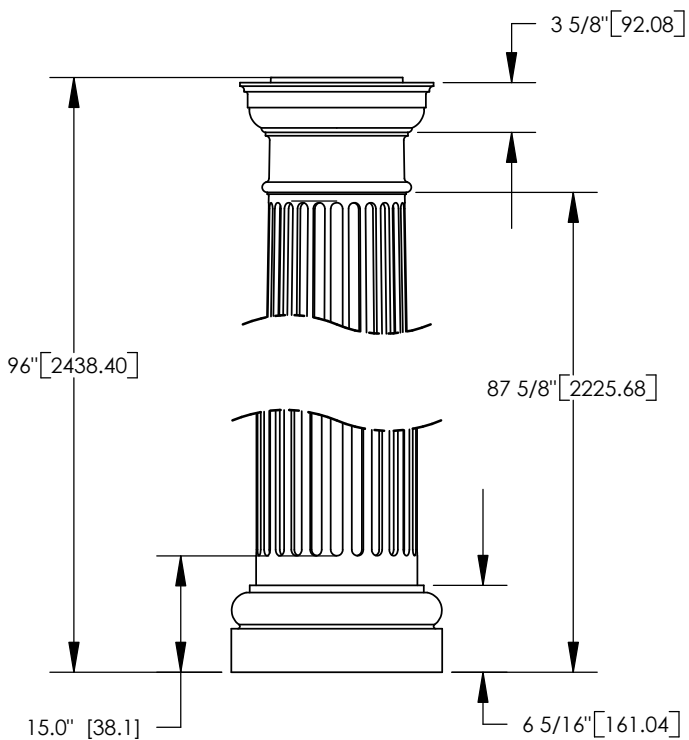
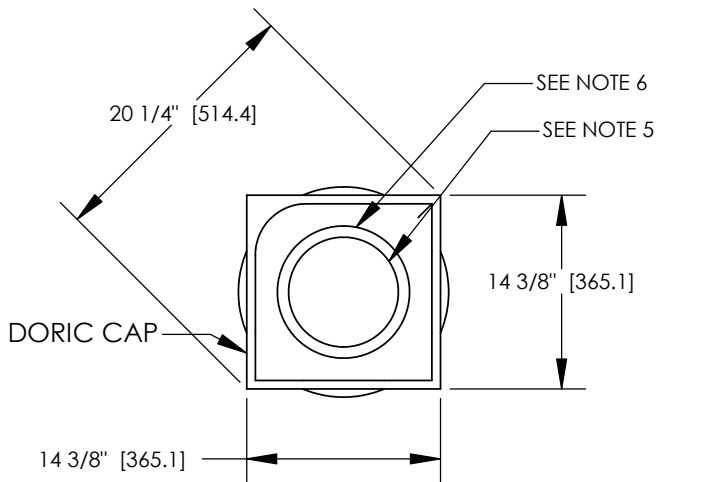

Column & Post, Inc.TM
8013 Purfoy Road
Fuquay-Varina, NC 27526
Tel: (919) 255-1533
Fax: (919) 255-1553
E-Mail: www.columnpost.com

			DIMENSIONS ARE IN INCHES (mm) TOLERANCES: FRACTIONAL ± 1/8" ANGULAR: MACH ± BEND ± TWO PLACE DECIMAL ± THREE PLACE DECIMAL ±
			MATERIAL
			FINISH
NEXT ASSY	USED ON		
APPLICATION		DO NOT SCALE DRAWING	

	NAME	DATE
DRAWN	SOF	05/05/08
CHECKED	RK	
ENG APPR.	RK	
MFG APPR.	RK	
Q.A.	RK	
COMMENTS:		

© COPYRIGHT Column & Post, Inc.		
12" X 8" FLUTED COLUMN W/ DORIC CAP & TUSCAN BASE ASSEMBLY		
SIZE A	DWG. NO.	REV. 02
SCALE: 1/14		WEIGHT:
		SHEET 1 OF 1