

- NOTES:
1. DIMENSIONS WITHIN THE PARENTHESES ARE METRIC UNITS (millimeter) or (Kg=kilograms)
  2. MATERIAL: FIBERGLASS REINFORCED POLYMER (FRP)
  3. WEIGHT. COLUMN: 130 Lb. (59.0 Kg)  
CAP: 14 Lb. (6.4 Kg)  
BASE: 17 Lb. (7.7 Kg)
  4. MATERIAL THICKNESS. COLUMN: 3/8" (9.5)
  5. INSIDE DIAMETER AT TOP OF COLUMN: 8 1/4" (209.6)
  6. OUTSIDE DIAMETER AT TOP OF COLUMN: 9 1/4" (235.0)
  7. INSIDE DIAMETER AT BOTTOM OF COLUMN: 10 3/4" (273.1)
  8. OUTSIDE DIAMETER AT BOTTOM OF COLUMN: 11 1/4" (285.8)
  9. TAPER STARTS 43.0" (1092.2) FROM BOTTOM OF COLUMN.
  10. 24 FLUTES

COLUMN PROJECTS 1/4" (6.35) ABOVE STANDARD CAPITAL.

DORIC CAP

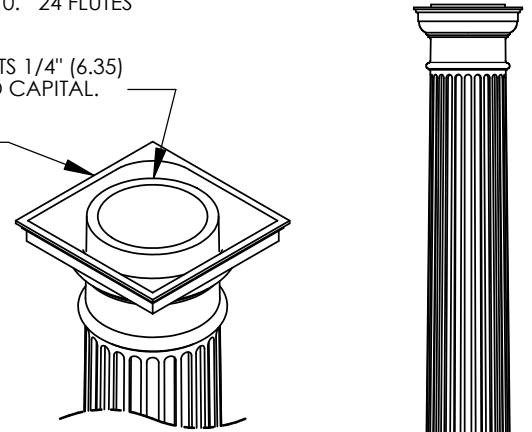

12" X 10' FLUTEDE COLUMN

TUSCAN BASE

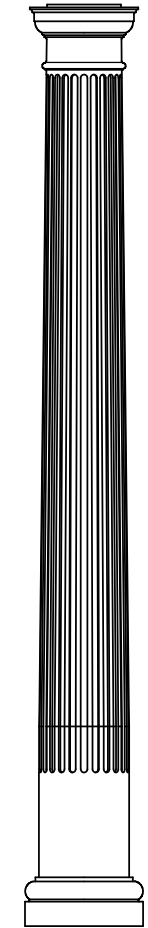
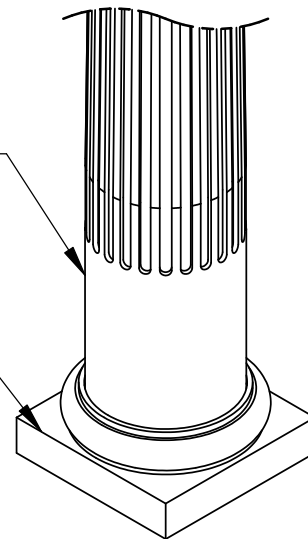

ARCHITECTURAL VIEW  
SCALE 1/25

Column & Post, Inc.<sup>TM</sup>  
8013 Purfoy Road  
Fuquay-Varina, NC 27526  
Tel: (919) 255-1533  
Fax: (919) 255-1553  
E-Mail: www.columnpost.com

		DIMENSIONS ARE IN INCHES (mm) TOLERANCES: FRACTIONAL ± 1/8" ANGULAR: MACH ± BEND ± TWO PLACE DECIMAL ± THREE PLACE DECIMAL ±
		MATERIAL
		FINISH
NEXT ASSY	USED ON	
APPLICATION		DO NOT SCALE DRAWING

	NAME	DATE
DRAWN	SOF	05/05/08
CHECKED	RK	
ENG APPR.	RK	
MFG APPR.	RK	
Q.A.	RK	

COMMENTS:

© COPYRIGHT  
Column & Post, Inc. 2002

12" X 10' FLUTED COLUMN  
W/ DORIC CAP  
& TUSCAN BASE  
ASSEMBLY

SIZE	DWG. NO.	REV.
A		02
SCALE: 1/14		WEIGHT:
		SHEET 1 OF 1