

- NOTES:
1. DIMENSIONS WITHIN THE PARENTHESES ARE METRIC UNITS (millimeters) OR (Kg=Kilograms)
 2. MATERIAL: FIBERGLASS REINFORCED POLYMER (FRP)
 3. WEIGHT. COLUMN: 73Lb. (33.1 Kg)
CAP: 5Lb. (2.3 Kg.)
BASE: 7Lb. (3.2 Kg.)
 4. MATERIAL THICKNESS: 3/8" (9.5)
 5. MAXIMUM LOAD BEARING LIMITS: 10,000 Lb. (4535.9 Kg.)

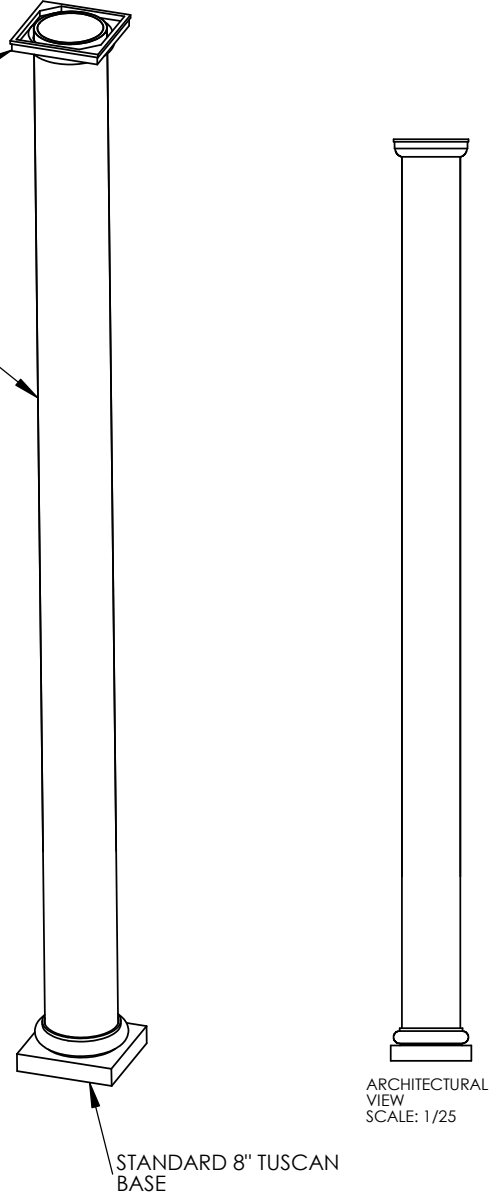
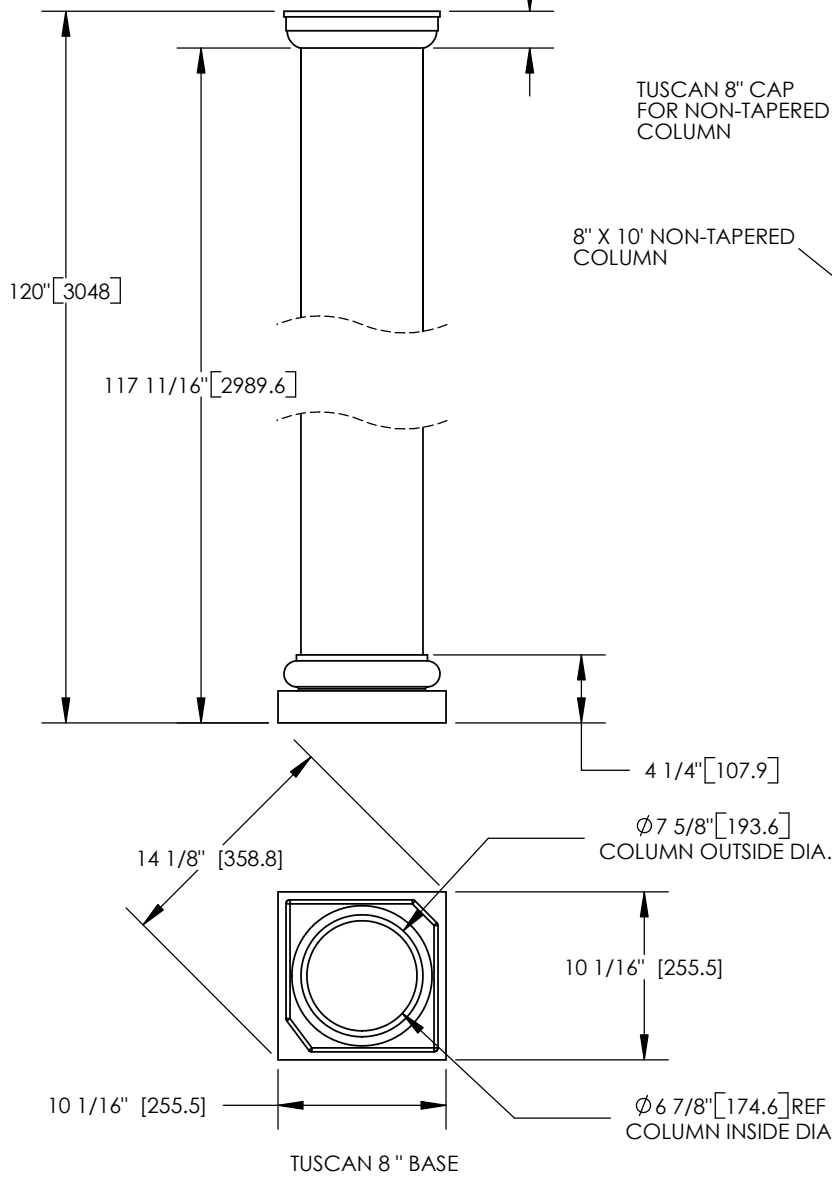

COLUMN & POST, Inc.™
8013 Purfoy Road
Fuquay-Varina, NC 27526
Tel: (919) 255-1533
Fax: (919) 255-1553
E-Mail: www.columnpost.com

		DIMENSIONS ARE IN INCHES TOLERANCES: FRACTIONAL ± 1/8" ANGULAR: MACH ± BEND ± TWO PLACE DECIMAL ± THREE PLACE DECIMAL ±			
		MATERIAL			
		FINISH			
NEXT ASSY	USED ON				
APPLICATION		DO NOT SCALE DRAWING			

	NAME	DATE
DRAWN	SOF	05/05/08
CHECKED	RK	
ENG APPR.	RK	
MFG APPR.	RK	
Q.A.	RK	
COMMENTS:		

©COPYRIGHT Column & Post, Inc. 2002		
8" x 10' TUSCAN NON-TAPERED COLUMN ASSEMBLY		
SIZE A	DWG. NO.	REV. 02
SCALE: 1:12		SHEET 1 OF 1