

- NOTES:
1. DIMENSIONS WITHIN THE PARENTHESES ARE METRIC UNITS (millimeters) OR (Kg=Kilograms)
 2. MATERIAL: FIBERGLASS REINFORCED POLYMER (FRP)
 3. WEIGHT. COLUMN: 83Lb. (37.6 Kg)
CAP: 8Lb. (3.6 Kg.)
BASE: 15Lb. (6.8 Kg.)
 4. MATERIAL THICKNESS: 3/8" (9.5)
 5. MAXIMUM LOAD BEARING LIMITS: 14000 Lb. (6350.3 Kg.)

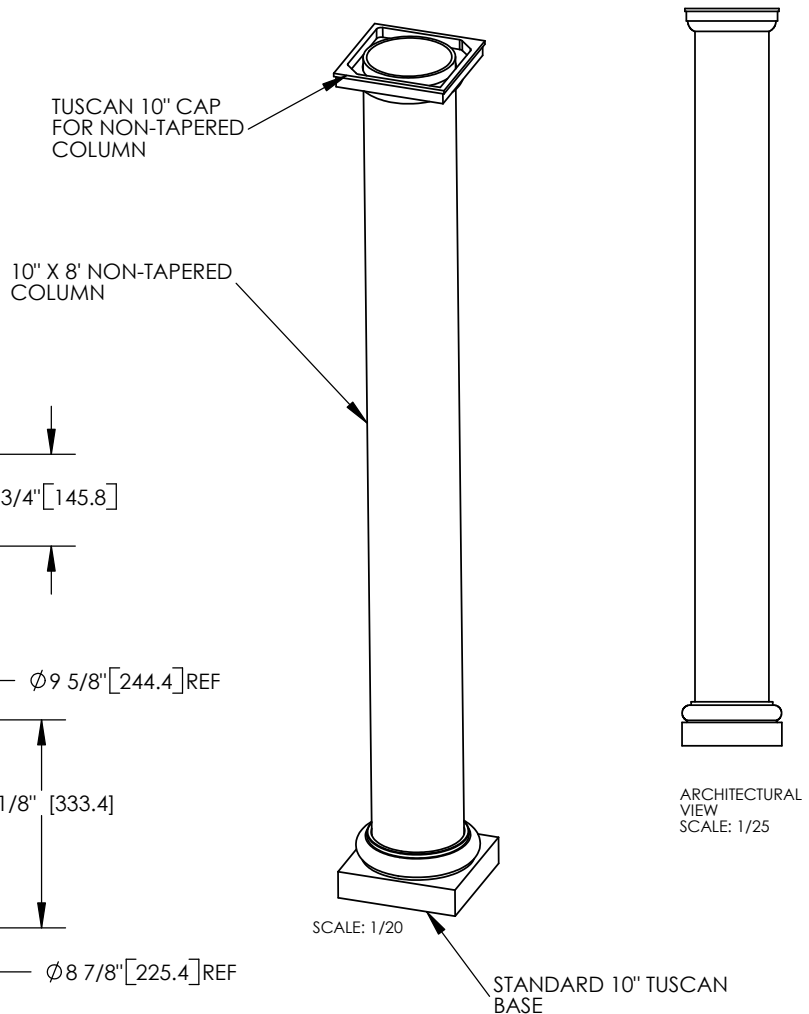
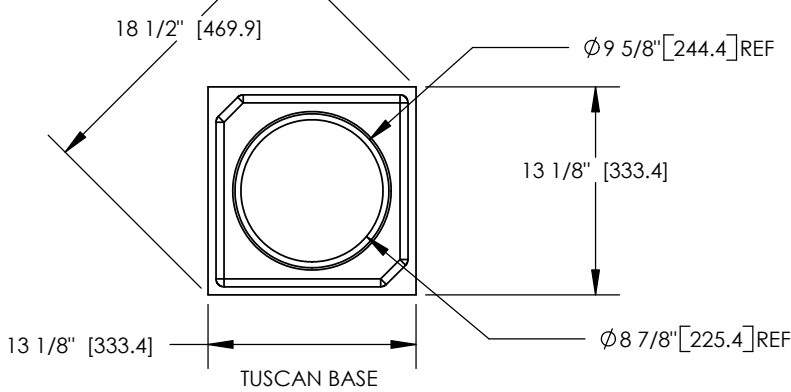
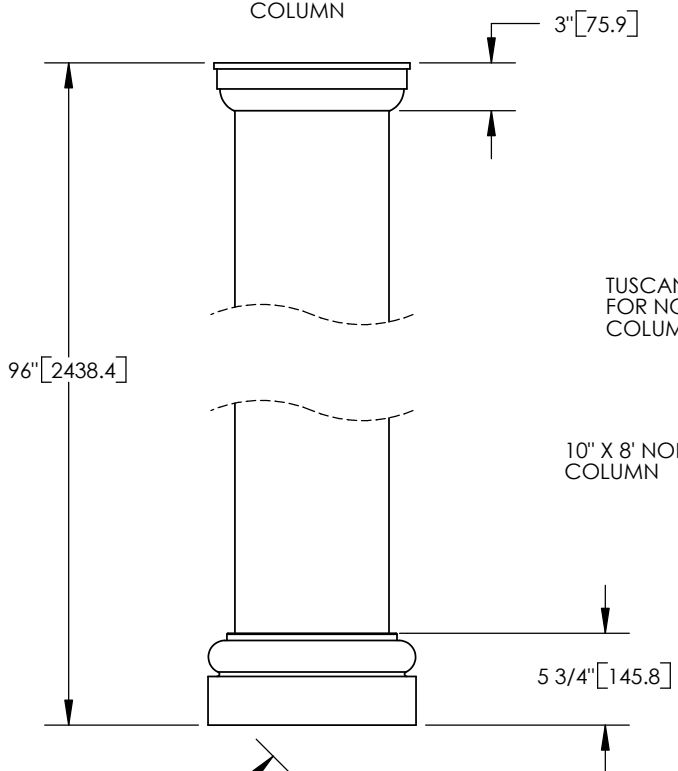

COLUMN & POST, Inc.™
8013 Purfoy Road
Fuquay-Varina, NC 27526
Tel: (919) 255-1533
Fax: (919) 255-1553
E-Mail: www.columnpost.com

		DIMENSIONS ARE IN INCHES TOLERANCES: FRACTIONAL ± 1/8" ANGULAR: MACH ± BEND ± TWO PLACE DECIMAL ± THREE PLACE DECIMAL ±	NAME	DATE
			DRAWN	SOF 05/05/08
			CHECKED	RK
			ENG APPR.	RK
			MFG APPR.	RK
		MATERIAL	Q.A.	RK
NEXT ASSY	USED ON	FINISH	COMMENTS:	
APPLICATION		DO NOT SCALE DRAWING		

©COPYRIGHT Column & Post, Inc. 2002		
10" x 8" TUSCAN NON-TAPERED COLUMN ASSEMBLY		
SIZE A	DWG. NO.	REV. 02
SCALE: 1:12	SHEET 1 OF 1	