

- NOTES:
1. DIMENSIONS WITHIN THE PARENTHESES ARE METRIC UNITS (millimeters) OR (Kg=Kilograms)
 2. MATERIAL: FIBERGLASS REINFORCED POLYMER (FRP)
 3. WEIGHT. COLUMN: 130Lb. (58.9 Kg)
CAP: 8Lb. (3.6 Kg.)
BASE: 15Lb. (6.8 Kg.)
 4. MATERIAL THICKNESS: 3/3" (9.5)
 5. MAXIMUM LOAD BEARING LIMITS: 14000 Lb. (6350.3 Kg.)

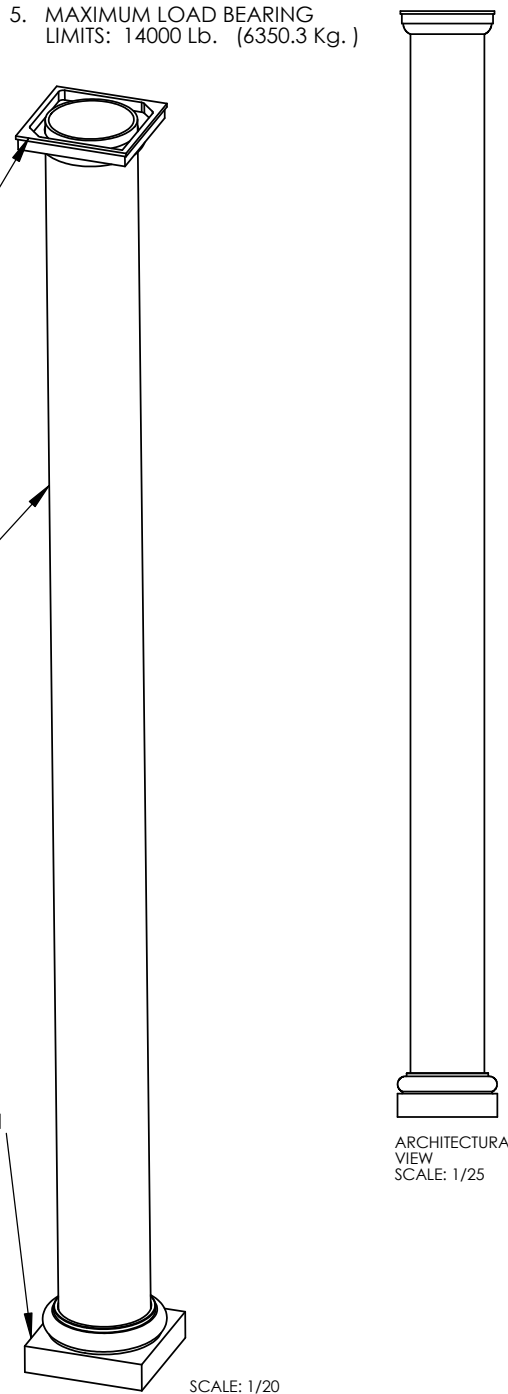
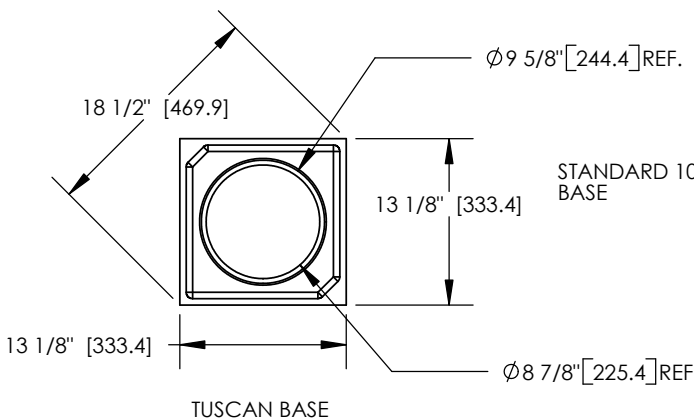
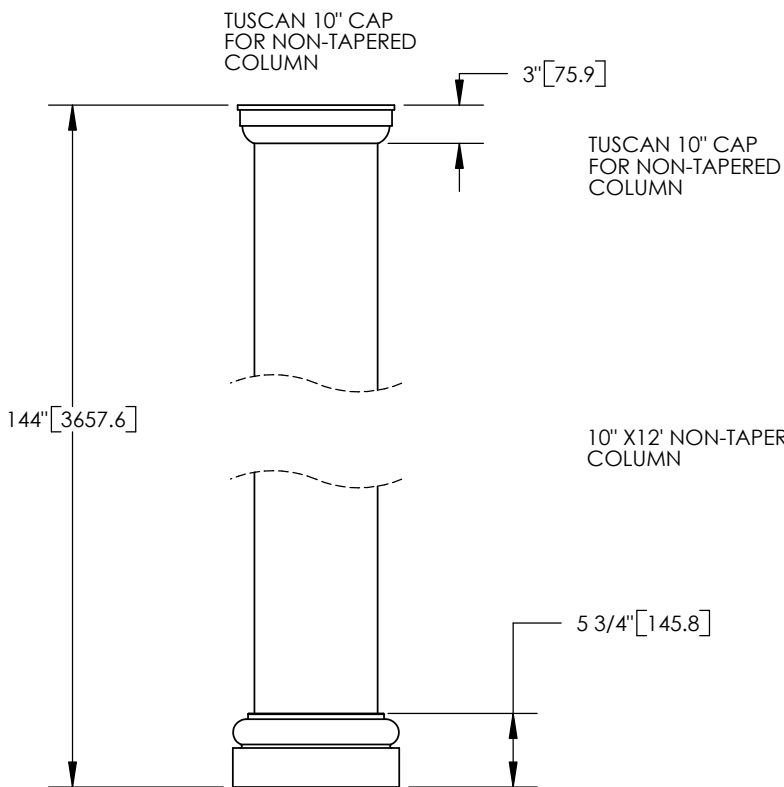

COLUMN & POST, Inc.™
 8013 Purfoy Road
 Fuquay-Varina, NC 27526
 Tel: (919) 255-1533
 Fax: (919) 255-1553
 E-Mail: www.columnpost.com

		DIMENSIONS ARE IN INCHES TOLERANCES: FRACTIONAL $\pm 1/8$ " ANGULAR: MACH \pm BEND \pm TWO PLACE DECIMAL \pm THREE PLACE DECIMAL \pm		NAME	DATE
			DRAWN	SOF	05/05/08
			CHECKED	RK	
			ENG APPR.	RK	
			MFG APPR.	RK	
		MATERIAL		Q.A.	RK
		FINISH	COMMENTS:		
NEXT ASSY	USED ON	APPLICATION	DO NOT SCALE DRAWING		

©COPYRIGHT Column & Post, Inc. 2002		
10" x 12' TUSCAN NON-TAPERED COLUMN ASSEMBLY		
SIZE	DWG. NO.	REV.
A		02
SCALE: 1:15		SHEET 1 OF 1