

NOTES:

1. DIMENSIONS WITHIN THE PARENTHESES ARE METRIC UNITS (millimeters) or (Kg=Kilograms)
2. MATERIAL: FIBERGLASS REINFORCED POLYMER (FRP)
3. WEIGHT. COLUMN:
CAP:
BASE:
4. MATERIAL THICKNESS.
COLUMN: 3/8" (9.5)
5. INSIDE DIMENSION AT TOP OF COLUMN: 6 3/4" (171.5)
6. OUTSIDE DIMENSION AT TOP OF COLUMN: 7 1/2" (190.5)
7. INSIDE DIMENSION AT BOTTOM OF COLUMN: 7 1/4" (184.2)
8. OUTSIDE DIMENSION AT BOTTOM OF COLUMN: 8" (203.2)

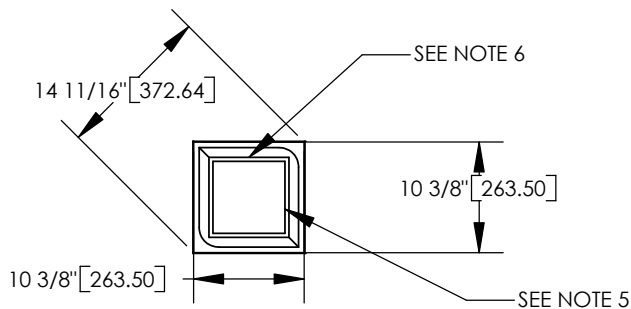

SQUARE TUSCAN
8" CAP

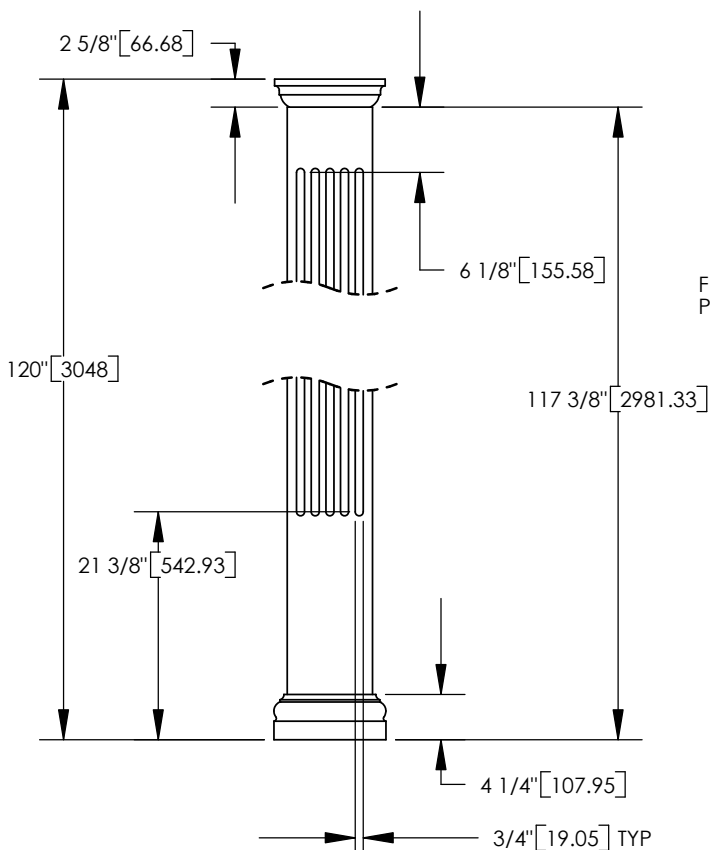

SQUARE TUSCAN
8" BASE

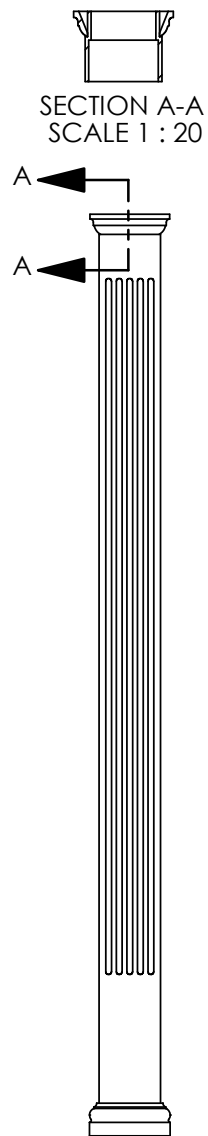
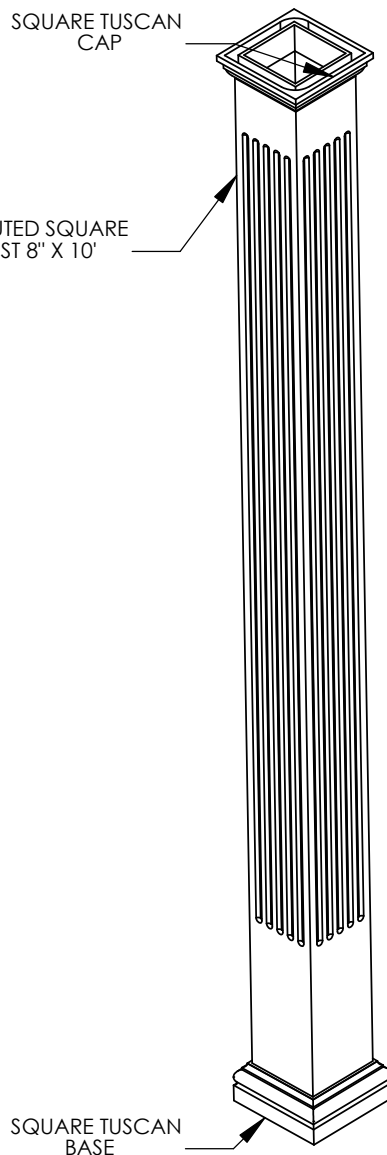

ARCHITECTURAL
VIEW
SCALE 1/25

Column & Post, Inc.TM
8013 Purfoy Road
Fuquay-Varina, NC 27526
Tel: (919) 255-1533
Fax: (919) 255-1553
E-Mail: www.columnpost.com

		DIMENSIONS ARE IN INCHES (mm) TOLERANCES: FRACTIONAL ± 1/8" ANGULAR: MACH ± BEND ± TWO PLACE DECIMAL ± THREE PLACE DECIMAL ±			
			MATERIAL		
NEXT ASSY	USED ON		FINISH		
APPLICATION			DO NOT SCALE DRAWING		

	NAME	DATE
DRAWN	SOF	05/05/08
CHECKED	RK	
ENG APPR.	RK	
MFG APPR.	RK	
Q.A.	RK	

COMMENTS:		
SIZE	DWG. NO.	REV.
A		02
SCALE: 1/18	WEIGHT:	SHEET 1 OF 1

© COPYRIGHT
Column & Post, Inc. 2002

8"X 10' SQUARE
FLUTED POST
ASSEMBLY