

**SQUARE TUSCAN
10" CAP**

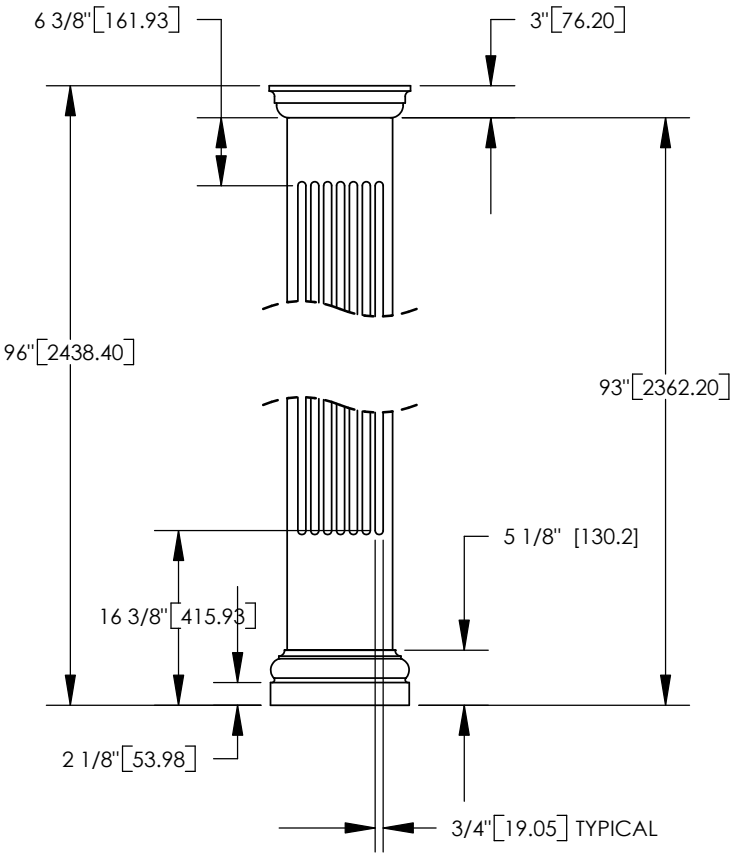

**SQUARE TUSCAN
10" BASE**

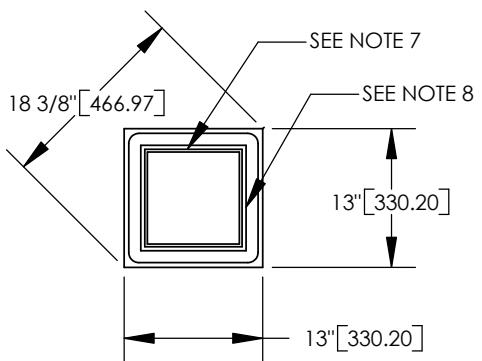

- NOTES:
1. DIMENSIONS WITHIN THE PARENTHESES ARE METRIC UNITS (millimeters) or (Kg=Kilograms)
 2. MATERIAL: FIBERGLASS REINFORCED POLYMER (FRP)
 3. WEIGHT. COLUMN:
CAP:
BASE:
 4. MATERIAL THICKNESS.
COLUMN: 3/8" (9.5)
 5. INSIDE DIMENSION AT TOP OF COLUMN: 8 5/8" (219.1)
 6. OUTSIDE DIMENSION AT TOP OF COLUMN: 9 3/8" (238.1)
 7. INSIDE DIMENSION AT BOTTOM OF COLUMN: 9 1/8" (231.8)
 8. OUTSIDE DIMENSION AT BOTTOM OF COLUMN: 9 7/8" (250.8)

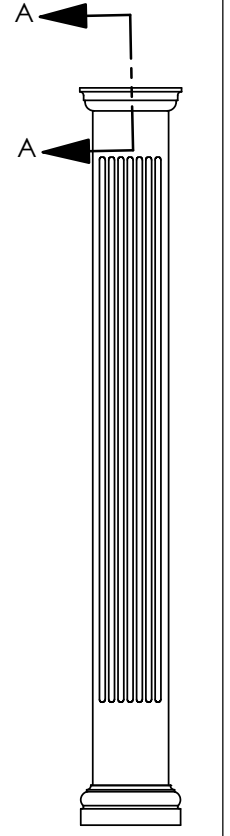
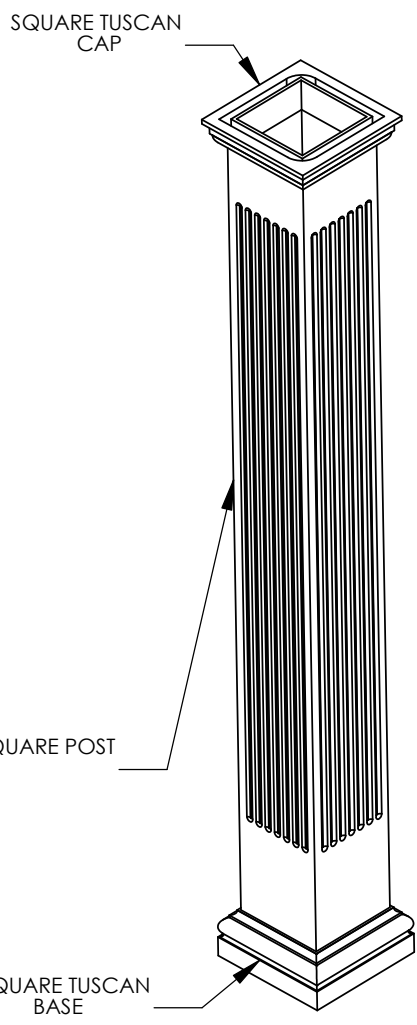
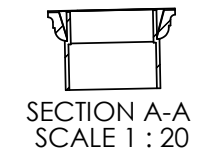

ARCHITECTURAL
VIEW
SCALE 1/25

DIMENSIONS ARE IN INCHES (mm)
TOLERANCES:
FRACTIONAL ± 1/8"
ANGULAR: MACH ±
BEND ±
TWO PLACE DECIMAL ±
THREE PLACE DECIMAL ±

NEXT ASSY	USED ON	FINISH
APPLICATION		DO NOT SCALE DRAWING

	NAME	DATE
DRAWN	SOF	05/05/08
CHECKED	RK	
ENG APPR	RK	
MFG APPR	RK	
Q.A.	RK	
COMMENTS:		

© COPYRIGHT
Column & Post, Inc. 2002

**10" X 8' SQUARE
FLUTED POST
ASSEMBLY**

Column & Post, Inc.TM
8013 Purfoy Road
Fuquay-Varina, NC 27526
Tel: (919) 255-1533
Fax: (919) 255-1553
E-Mail: www.columnpost.com

SIZE A	DWG. NO.	REV. 02
SCALE: 1/18	WEIGHT:	SHEET 1 OF 1