

**TUSCAN DROP-DOWN CAP**

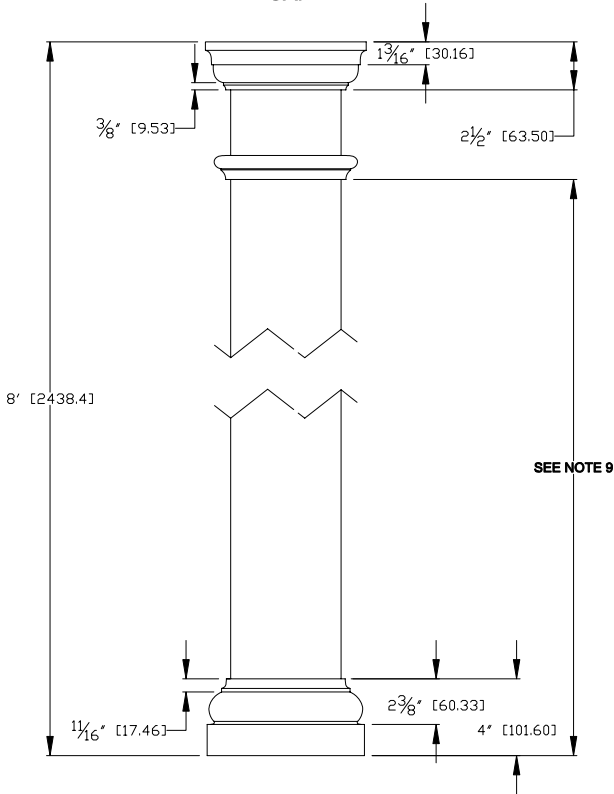

**TUSCAN BASE**

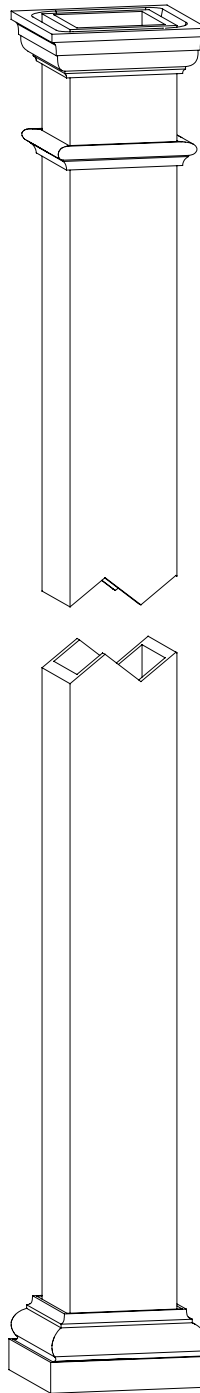
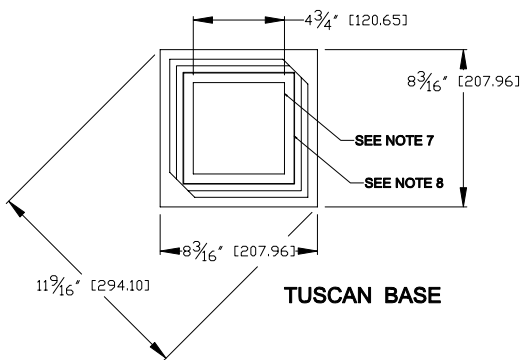

**ARCHITECTURAL VIEW  
SCALE: 1/25**

**NOTES:**

1. DIMENSIONS WITHIN THE PARENTHESES ARE METRIC UNITS (millimeters) or (Kg=Kilograms)
2. MATERIAL: FIBERGLASS REINFORCED POLYMER (FRP)
3. WEIGHT: POST: 58 lbs. [26.31]  
CAP: 2.625 lbs. [1.19]  
BASE: 4.625 lbs. [2.09]  
NECK RING: 1 lb. [0.45]
4. MATERIAL THICKNESS.  
POST: 1/2" [12.7]
5. INSIDE DIAMETER AT TOP OF POST: 4 3/4" [120.65]
6. OUTSIDE DIAMETER AT TOP OF POST: 5 3/4" [146.05]
7. INSIDE DIAMETER AT BOTTOM OF POST: 4 3/4" [120.65]
8. OUTSIDE DIAMETER AT BOTTOM OF POST: 5 3/4" [146.05]
9. PLACEMENT OF NECK RING TO BE DETERMINED BY CUSTOMER.
10. MAXIMUM LOAD BEARING LIMITS: 10,000 Lb. (4535.9 Kg)

Column & Post, Inc.™  
8013 Purfoy Rd.  
Fuquay-Varina, NC 27526  
Tel: (919) 255-1533  
Fax: (919) 255-1553  
E-mail: david@columnpost.com

		DIMENSIONS ARE IN INCHES (mm)	
		TOLERANCES: FRACTIONAL ± 1/8"	
		ANGULAR: MACH±	
		BEND±	
		2 PLACE DECIMAL±	
		THREE PLACE DECIMAL±	
		MATERIAL	
		FINISH	
NEXT ASSY	USED ON		
APPLICATION	DO NOT SCALE DRAWING		

	NAME	DATE
DRAWN	NAK	
CHECKED		
ENG APPR.		
MFG APPR.		
Q.A.		

©COPYRIGHT  
Column & Post, Inc. 2008

**6" X 8' Square Drop-Down Assembly**

SIZE	DWG. NO.	REV.
<b>A</b>		01
SCALE: 1/10	WEIGHT:	SHEET 1 OF 1