

TUSCAN DROP-DOWN CAP

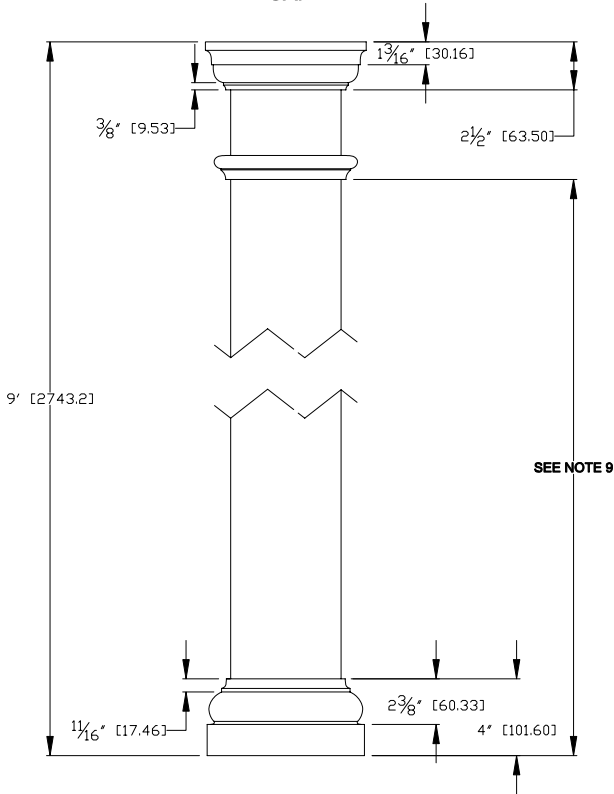

SEE NOTE 9

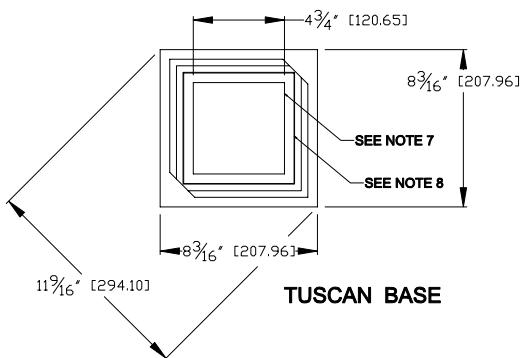

TUSCAN BASE

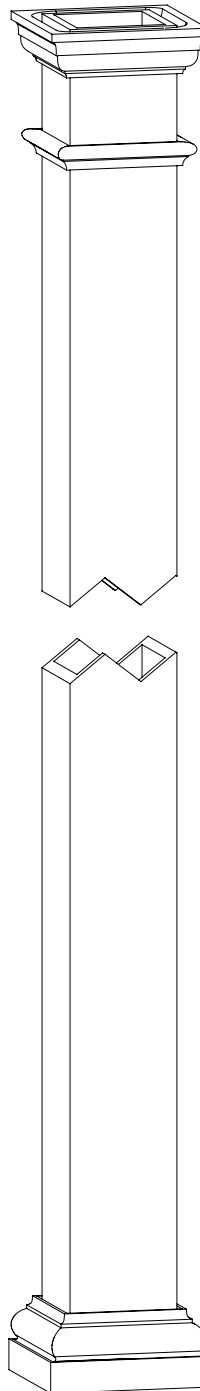

**ARCHITECTURAL VIEW
SCALE: 1/25**

NOTES:

1. DIMENSIONS WITHIN THE PARENTHESES ARE METRIC UNITS (millimeters) or (Kg=Kilograms)
2. MATERIAL: FIBERGLASS REINFORCED POLYMER (FRP)
3. WEIGHT: POST: 66 lbs. [29.94]
CAP: 2.625 lbs. [1.19]
BASE: 4.625 lbs. [2.09]
NECK RING: 1 lb. [0.45]
4. MATERIAL THICKNESS.
POST: 1/2" [12.7]
5. INSIDE DIAMETER AT TOP OF POST: 4 3/4" [120.65]
6. OUTSIDE DIAMETER AT TOP OF POST: 5 3/4" [146.05]
7. INSIDE DIAMETER AT BOTTOM OF POST: 4 3/4" [120.65]
8. OUTSIDE DIAMETER AT BOTTOM OF POST: 5 3/4" [146.05]
9. PLACEMENT OF NECK RING TO BE DETERMINED BY CUSTOMER.
10. MAXIMUM LOAD BEARING LIMITS: 10,000 Lb. (4535.9 Kg)

Column & Post, Inc.™
8013 Purfoy Rd.
Fuquay-Varina, NC 27526
Tel: (919) 255-1533
Fax: (919) 255-1553
E-mail: david@columnpost.com

		DIMENSIONS ARE IN INCHES (mm) TOLERANCES: FRACTIONAL ± 1/8" ANGULAR: MACH± BEND± 2 PLACE DECIMAL± THREE PLACE DECIMAL±	NAME	DATE
			DRAWN	NAK
			CHECKED	
			ENG APPR.	
		MFG APPR.		
			Q.A.	
		MATERIAL		
		FINISH		
NEXT ASSY	USED ON			
APPLICATION	DO NOT SCALE DRAWING			

©COPYRIGHT
Column & Post, Inc. 2008

6" X 9' Square Drop-Down Assembly

SIZE	DWG. NO.	REV.
A		01
SCALE: 1/10	WEIGHT:	SHEET 1 OF 1