

NOTES:

1. DIMENSIONS WITHIN THE PARENTHESES ARE METRIC UNITS (millimeters) or (Kg=Kilograms)
2. MATERIAL: FIBERGLASS REINFORCED POLYMER (FRP)
3. WEIGHT. COLUMN:
CAP:
BASE:
4. MATERIAL THICKNESS.
COLUMN: 3/8" (9.5)
5. INSIDE DIMENSION AT TOP OF COLUMN: 12 5/8" (330.7)
6. OUTSIDE DIMENSION AT TOP OF COLUMN: 13 3/8" (339.7)
7. INSIDE DIMENSION AT BOTTOM OF COLUMN: 13 3/8" (339.73)
8. OUTSIDE DIMENSION AT BOTTOM OF COLUMN: 14 1/8" (358.8)

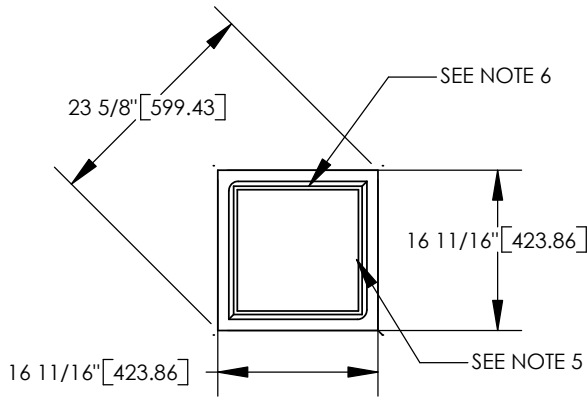

SQUARE TUSCAN
1 3/4" X 1 3/4" 14" CAP

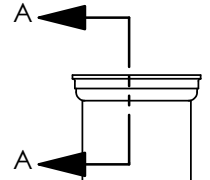
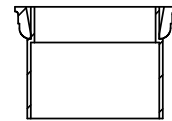
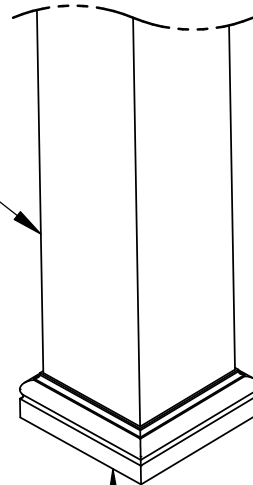
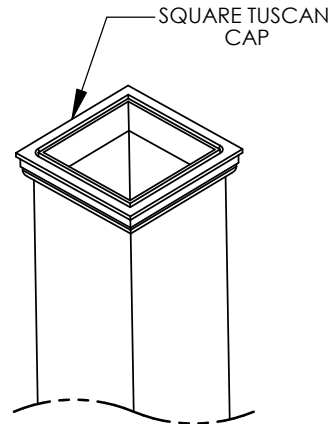
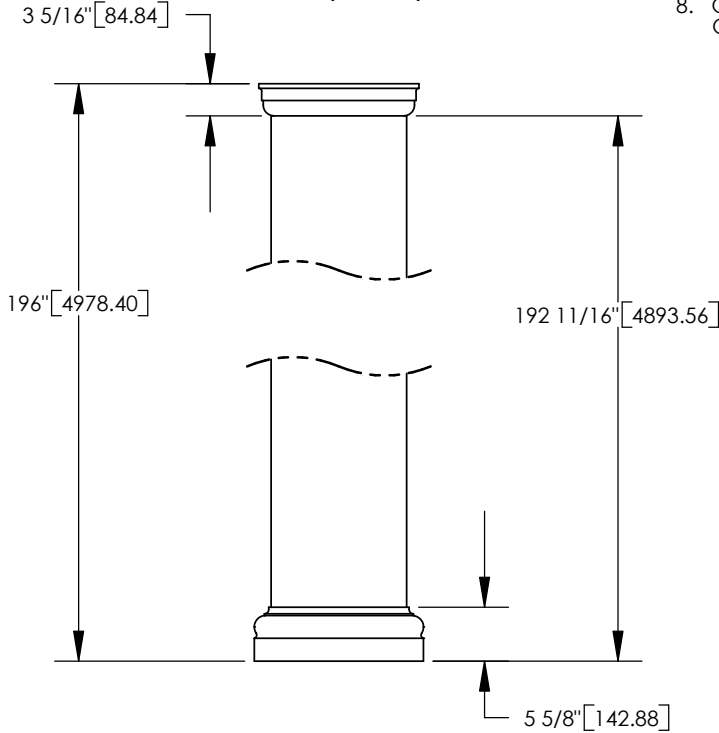

SECTION A-A
SCALE 1 : 20

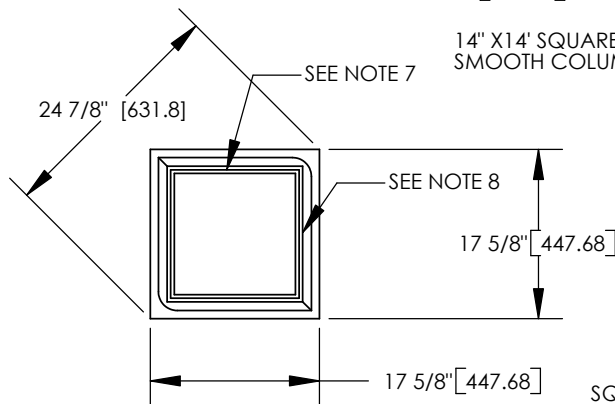

SQUARE TUSCAN
BASE

SQUARE TUSCAN
14" BASE

ARCHITECTURAL
VIEW
SCALE 1/25

		DIMENSIONS ARE IN INCHES (mm) TOLERANCES: FRACTIONAL ± 1/4" ANGULAR: MACH ± BEND ± TWO PLACE DECIMAL ± THREE PLACE DECIMAL ±	NAME	DATE	© COPYRIGHT Column & Post, Inc. 2002	
			DRAWN	SOF		05/05/08
			CHECKED	RK		
			ENG APPR.	RK		
			MFG APPR.	RK		
		MATERIAL	Q.A.	RK	14" X 14' TUSCAN SQUARE SMOOTH COLUMN ASSEMBLY	
		FINISH	COMMENTS:			
NEXT ASSY	USED ON					
APPLICATION		DO NOT SCALE DRAWING				
Column & Post, Inc. TM 8013 Purfoy Road Fuquay-Varina, NC 27526 Tel: (919) 255-1533 Fax: (919) 255-1553 E-Mail: www.columnpost.com		SIZE	DWG. NO.	REV.		
		A		02		
		SCALE: 1/20	WEIGHT:	SHEET 1 OF 1		