

- NOTES:
1. DIMENSIONS WITHIN THE PARENTHESES ARE METRIC UNITS (millimeter) or (Kg=Kilograms)
 2. MATERIAL: FIBERGLASS REINFORCED POLYMER (FRP)
 3. WEIGHT:

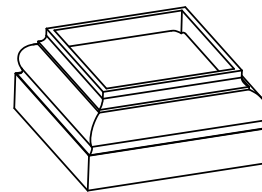
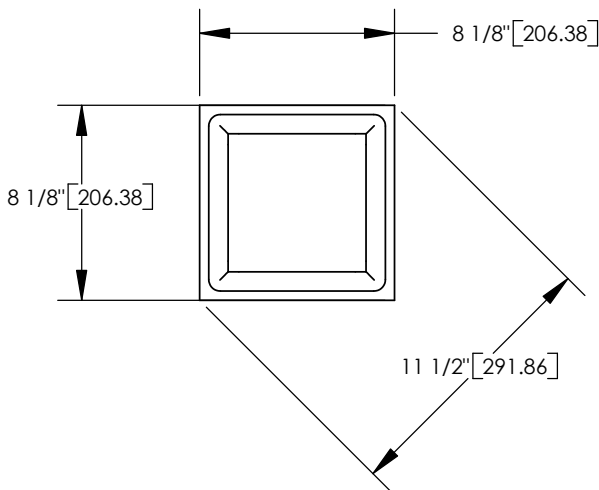
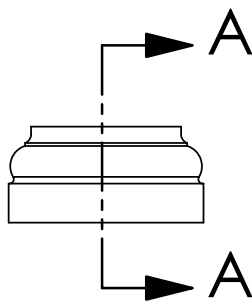
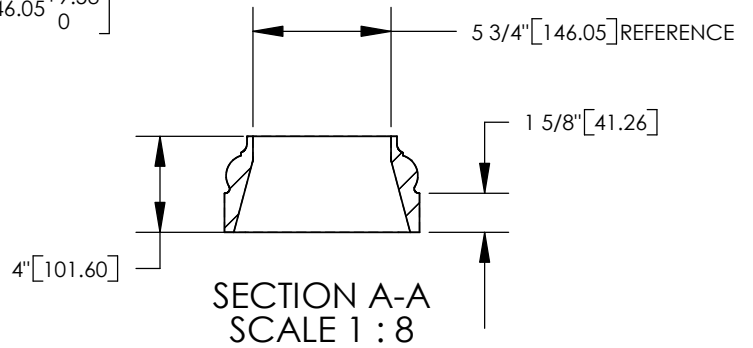

ARCHITECTURAL VIEW
SCALE: 1/25

Column & Post, Inc.TM
8013 Purfoy Road
Fuquay-Varina, NC 27511
Tel: (919) 255-1533
Fax: (919) 255-1553
E-Mail: www.columnpost.com

		DIMENSIONS ARE IN INCHES TOLERANCES: FRACTIONAL ±1/8 ANGULAR: MACH ± BEND ± TWO PLACE DECIMAL ± THREE PLACE DECIMAL ±	NAME	DATE	© COPYRIGHT COLUMN & POST, Inc. 2002 TUSCAN SQUARE 6 INCH BASE	
			DRAWN	SOF		05/05/08
			CHECKED	RK		
			ENG APPR.	RK		
			MFG APPR.	RK		
		MATERIAL	Q.A.	RK		
		FINISH	COMMENTS:			
NEXT ASSY	USED ON				SIZE A	
APPLICATION		DO NOT SCALE DRAWING			DWG. NO.	
					SCALE: 1/8	
					WEIGHT:	
					REV. 02	
					SHEET 1 OF 1	